

# Operation instruction

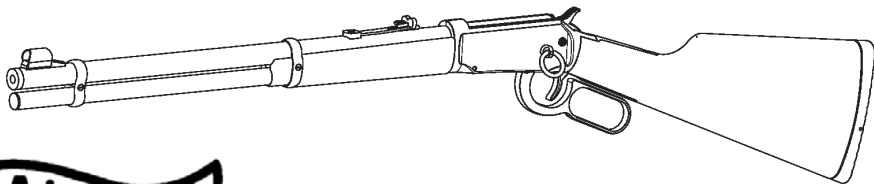

**WALTHER**

CO<sub>2</sub>-rifle

**Mod. Lever action long**

**Mod. Lever action short**

Cal. .177 (4,5mm)



Patent applied for



This weapon can be acquired for free according to respective legal requirements of a land. For your own safety and for the safety of others, please study these instructions carefully prior to shooting with the weapon.

Buyers and owners are obliged to know and follow the rules for safe handling and ownership of CO<sub>2</sub>-rifles.



This symbol indicates safety instructions contained in this operation instruction. When you see this symbol, please be especially attentive and read the marked section carefully. Load the pellets immediately prior to shooting. When the weapon is loaded and you decide not to shoot then unload the weapon following these instructions. An unloaded weapon with its safety on "safe" is the safest weapon. Accidents happen easily, and the consequences can be serious. Accidents can cause serious injuries or can have fatal consequences. Please be extremely careful when firing a weapon!



Even though your new CO<sub>2</sub>-rifle is not a fullbore firearm it still is a weapon, and it should therefore be treated with caution and respect. Always bear in mind that the first and more important safety aspect of every weapon is its user. All safeties are mechanical devices, and the shooter is the only one who operates these devices. **DO NOT RELY ON MECHANICAL SAFETIES** - act prudently and avoid situations which could result in an accident!

Different weapons require different ways of handling. You should never fire a weapon with which you are not familiar. Read the following operation instructions and practice the handling of your weapon **WITH THE WEAPON IN UNLOADED CONDITION** (dry-firing on a safe target) so that you are able to operate your weapon correctly and safely.

### **Rules for the safe use of a weapon:**

1. Learn to know the components of your new CO<sub>2</sub>-rifle
2. Operation of the safety
3. Loaded magazine indicator
4. Insertion and removal of the CO<sub>2</sub>-cylinder
5. Loading the rotary magazine
6. Loading the rifle
7. Safe aiming and firing
8. Stoppages
9. CO<sub>2</sub> - characteristic features
10. Setting the sights
11. Storage
12. Care and maintenance
13. Problems
14. Changes and modifications to the weapon
15. Repair of WALTHER-weapons
16. Warranty for WALTHER-weapons
17. General handling cautions
18. Technical data
19. Spare parts



Never leave a loaded weapon unattended!

A weapon should be kept and stored in unloaded condition only. Put the safety on "safe", carefully make sure that there is no pellet in the barrel, remove CO<sub>2</sub>-cylinder. Keep weapon away from children and unauthorized persons. Pellets and CO<sub>2</sub>-cylinders are to be kept separately from the weapon in order to prevent unauthorized use of the weapon by children and other unauthorized persons.

## 1. Learn to know the components of your new CO<sub>2</sub>-rifle

To memorise the designations of the single components of your new rifle will help you to understand the operation instructions. Read this handbook in order to be able to have as much fun as possible with your new weapon.

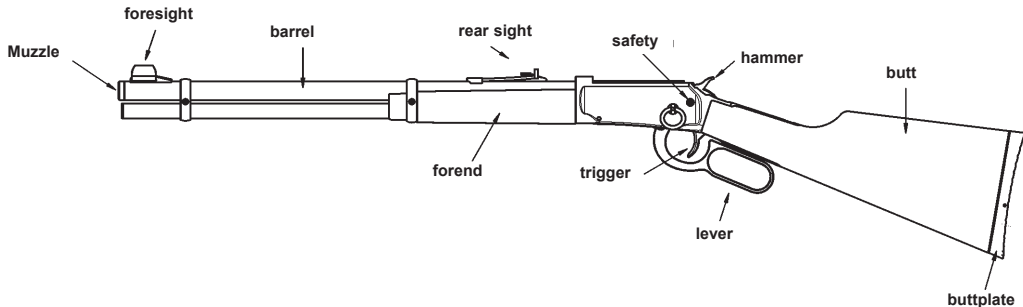

## 2. Operation of the safety

2.1 To activate the safety, push the safety button to the right (see fig. 1). The red marking is covered and thus not visible.

2.2 You should only handle a weapon the safety of which has been put on "safe". Always make sure that the muzzle points into a safe direction.

2.3 To deactivate the safety, push the safety button to the left (fig. 2) The red marking is now visible and the weapon is ready to fire (fig. 3).

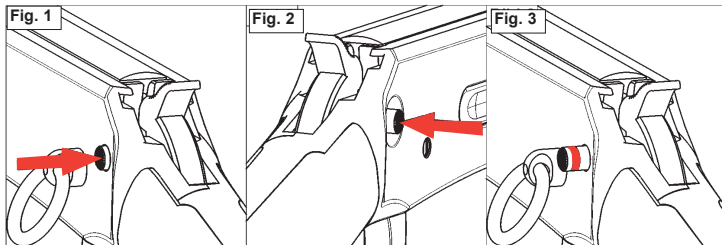

### CAUTION:

Make it a habit to always leave the weapon uncocked and to leave the safety activated until you are ready to fire.

## 3. Loaded rifle indicator

In order to immediately indicate that there is a magazine in the rifle, the gun is equipped with a loaded rifle indicator (fig. 4). Please note: As soon as the red indicator is visible, there is a magazine in the rifle and it should be handled with increased care.

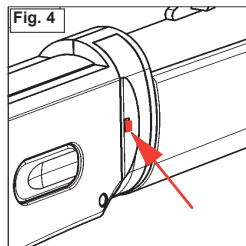

## 4. Insertion and exchange of CO<sub>2</sub> gas cylinders



**Caution:** When stabbing a CO<sub>2</sub> gas cylinder, it is to be made sure that the safety of the weapon is engaged and that the muzzle points to a safe direction.

**Note:** Only use CO<sub>2</sub> gas cylinders which contain 12 g of CO<sub>2</sub>, do not use any other cylinders containing other gases! Try to use gas cylinders which bear the marking "Lebensmittelecht" (fit for human consumption), do not use gas cylinders for industrial purposes. We recommend or own gas cylinders made by Walther (see chapter on special accessories).

Operate the butt lever (fig. 5 + 6) to remove the gas cylinder system from the butt (fig. 7), pull it to the rear. Loosen the cylinder holder by turning the upper lever (fig. 8). Remaining gas is now allowed to escape. Now the gas cylinders can be removed (fig. 9). Insert new gas cylinders with their slim ends to the front into the gas cylinder system and tighten the holding device. The gas cylinders will now be stabbed and sealed. Turn the lever to the front. The rib on the metal plate must interlock with the lever (fig. 10). Now insert the whole gas cylinder system into the butt. Make sure that the butt lever is fully open. Lock the system by locking the butt lever.

In order to make sure that the gas cylinders have been properly stabbed make sure that there is no magazine or pellet in the rifle and fire the gun into a safe direction. If the rifle fails to discharge, insert the gas cylinders again as described above.

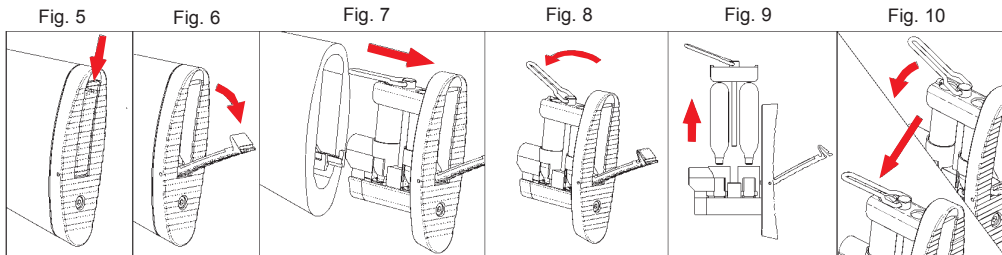



**CAUTION!** Never try to insert a CO<sub>2</sub>-cylinder by using force!

If the weapon is not to be used for some time, we recommend to remove the CO<sub>2</sub>-cylinders. This will relieve the system. Remove the gas cylinders as described in these instructions. Remaining gas may escape. Re-insert the cylinder mountings without the gas cylinders, insert the whole system into the butt and close it by pushing the lever fully home.



**CAUTION!** Keep face and hands in a safe distance from the CO<sub>2</sub>-cylinder. Escaping gas may cause icing.



**CAUTION!** CO<sub>2</sub>-cylinders may explode if exposed to temperatures exceeding 50° C. Do not destroy cylinders or throw them into a fire. Never expose cylinders to heat or store them at temperatures exceeding 50° C. Never try to use a used CO<sub>2</sub>-cylinder for any other purposes. Never leave CO<sub>2</sub>-cylinders in your car exposed to direct sunlight.

## 5. Loading the rotary magazine



**ATTENTION!** Always use pellets calibre .177 (4.5 mm) with a maximum projectile length of 6.5 mm. Never use steel shot (so-called BB's), other steel projectiles, darts or similar unsuitable projectiles.

- Load the rotary magazine with pellets cal. .177 (4.5 mm) by inserting the pellets with their heads pointing forward into the chambers of the magazine (fig. 11).
- Make sure that all pellets that the bases of the pellets are flush with the chambers ore that their are placed in the chambers slightly recessed (fig. 12). A pellet must never protrude from the magazine!
- Always use pellets with a maximum projectile length of 6.5 mm. Your new weapon was tested for flawless function with all kinds of pellets from the special accessories section.

Fig. 11

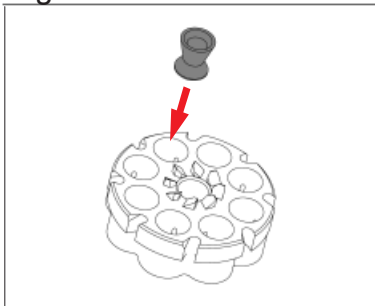
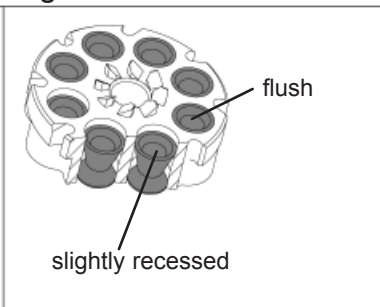

Fig. 12



## 6 Loading the rifle

- Engage the safety of your rifle (see chapter 2).
- open the hinged magazine holder by pressing the front part of the loading platform inside the ejection port (fig. 13).
- Place the rotary magazine on the hinged magazine holder and close the holder by pushing it fully home until it locks.
- **After the insertion of an loaded rotary magazine, the action of the rifle has to be cycled, in order to allow the magazine to fully enter its seat in the rifle. NOTE: Do not cock the hammer at this time.**



**ATTENTION!** Never put your hand in front of the muzzle! Keep your fingers off the trigger! Caution! Always make sure that the muzzle of your rifle points into a safe direction. Never aim at humans or animals.

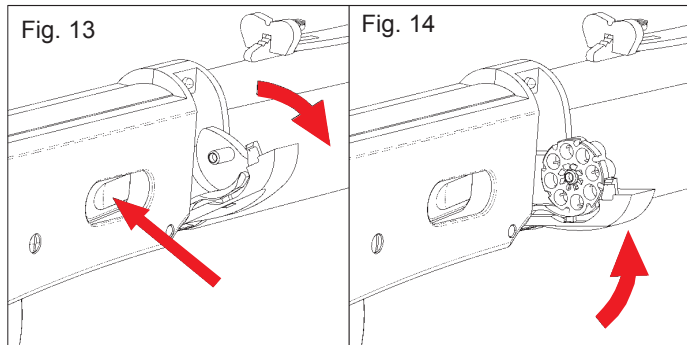

## 6.1 Unloading the rifle

- Engage the safety as described (see chapter 2).
- Open the magazine holder by pressing the loading platform (fig. 11).
- Remove the rotary magazine
- Close the magazine holder without the magazine on it



**ATTENTION!** Never use a sharp or pointed metal tool to remove the pellets from the rotary magazine or the weapon! A damaged magazine or barrel will lead to malfunctions.

- Make sure that the rifle is fully unloaded.
- A pellet in the barrel will have to be removed with the cleaning brush, or you may remove it by firing the rifle with an empty rotary magazine inserted.
- Never attempt to fire a used pellet a second time. Magazine and barrel could be damaged.

## 7. Safe aiming and firing



**ATTENTION!** Always make sure that the muzzle of your rifle points into a safe direction. Never aim at humans or animals. Always treat your weapon as if it was loaded and ready to fire.

Make sure that the safety of your weapon is on "safe". Insert the CO<sub>2</sub>-cylinder and load the rifle according to these instructions. As an experienced and safety-conscious shooter you make sure that your target is safe every time you pull the trigger.



**CAUTION!** As your rifle is a high-power weapon, you have to be very careful and prudent when you select a target. Only select targets which cannot be penetrated, avoid shooting at hard surfaces as this may result in ricochets. Never shoot at a liquid surface such as water!

## Cycling the action (loading)

After the weapon has been loaded as described, make sure that target, backstop and surrounding areas are clear and safe. After the insertion of an loaded rotary magazine, the action of the rifle has to be cycled, in order to allow the magazine to fully enter its seat in the rifle. Each time, you cycle the action, the magazine will rotate to the next position. Cycle the action by moving the lever fully down and then pushing it back up until it locks (fig. 15). Disengage the safety as described. Exert steady pressure onto the trigger until the hammer falls.

Fig. 15

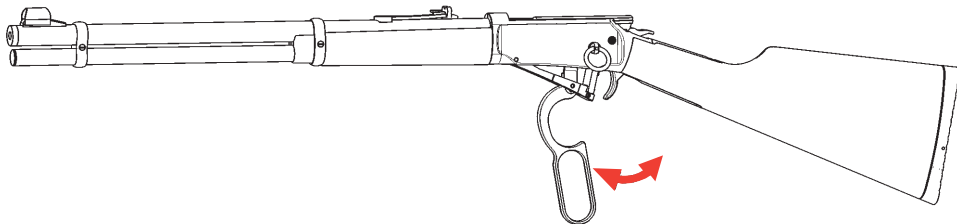

## 8. Stoppages



A stoppage is a dangerous condition of your rifle!



**ATTENTION!** The fact that the rifle does not fire a projectile is never a reason to assume that the rotary magazine does not contain any more pellets.

**CAUTION!** Firing the rifle with too little gas pressure left may cause a pellet to get stuck in the barrel.

- insert new CO<sub>2</sub>-cylinders and fire the rifle with the magazine empty.
- the pellet stuck in the barrel will now be fired
- if the problem is not solved by firing the rifle with an empty magazine inserted, remove the rotary magazine and carefully press the pellet back out by using a cleaning rod.

**CAUTION!** Removing a pellet from the barrel or incorrect operation of the rifle may cause a pellet to drop on the loading platform. The hinged magazine holder cannot be closed any more:

- push the pellet back into the loading space by using a flat tool (for example a toothpick)(fig. 16)
- remove the pellet from the loading space by shaking the rifle

Fig. 16

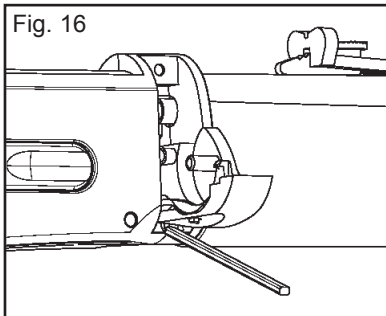

## 9. CO<sub>2</sub> - characteristic features

It may sometimes happen that a CO<sub>2</sub>-rifle is exposed to conditions which may have a negative influence on the performance of the gun. Among these are the use and/or the storage of the weapon at temperatures which are considerably higher or lower than the normal prevailing temperatures (15 - 21°C).

High temperatures may cause the CO<sub>2</sub>- gas in the gas cylinder or in the weapon itself to reach pressures which considerably exceed the normal working pressure. Such an excessive pressure may impede the firing of the rifle which could lead to lasting damages. The maximum temperature for the storage or use of this weapon should not exceed 50°C. This temperature can easily be reached when the weapon is exposed to direct sunlight.

**Always make sure that no CO<sub>2</sub>-cylinders are used the gas pressure of which has already reached a very low level.** Indicators for a low gas pressure can be the following:

- A) ) The noise caused by the discharge of the rifle is lower than normal (with a new gas cylinder)
- B) The point of impact of the pellets is lower than with a new gas cylinder (lower projectile velocity).



**CAUTION!** Firing the rifle with low gas pressure may cause a pellet to get stuck in the barrel. Refer to the instructions concerning stoppages.

## 10. Setting the sights

Take a safe aim with the rifle:

Hold the rifle in a way that the rear sight and the foresight (front sight) are aligned. The foresight must be right in the centre of the notch in the rear sight. Now lift the rifle so much that the centre of the target (bull's eye) touches the edge of the foresight with its lower edge. Upper edge of the rear sight - upper edge of the foresight - lower edge of the target centre have to be aligned (fig. 17). The point of impact can be adjusted according to the below described instructions. The sights have been adjusted for a firing distance of 10 m.

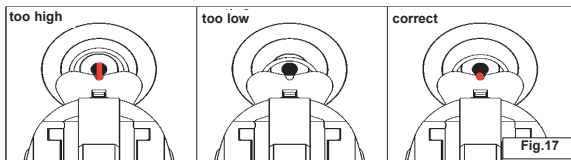

### Sight adjustment

**Elevation adjustment** is by moving the catch on the rear sight (fig. 18).

Point of impact too high: move sight blade to the front

Point of impact too low: move sight blade to the rear

**Windage adjustment** is by shifting the foresight blade. On the model Lever Action long, the foresight protection hood has to be removed prior to this operation (fig. 19).

Point of impact too far right: shift foresight blade to the right

Point of impact too far left: shift foresight blade to the left

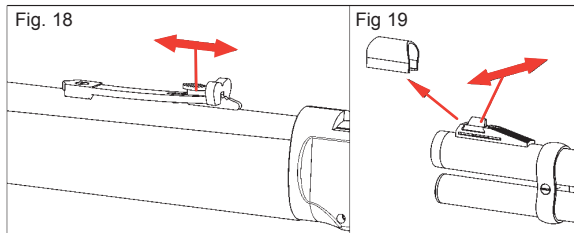

## 11. Storage



**Never leave a loaded weapon unattended!**

Storage of your weapon should always be in unloaded condition. Carefully make sure that there is no pellet in the barrel, remove CO<sub>2</sub>-cylinders and remove pellets from rotary magazine. Keep weapon away from children and unauthorized persons. Pellets and CO<sub>2</sub>-cylinders are to be stored separately from the rifle.

## 12. Care and maintenance

Good care and proper maintenance of your weapon will ensure that your rifle will give you pleasant shooting times for many years.



**ATTENTION!** Always unload the rifle, remove the CO<sub>2</sub>-cylinders and the rotary magazine and check the barrel to make sure that no pellet is left in it before you attempt to clean the weapon.

The outer surfaces of the metal parts have to be cleaned from time to time. Use a soft cloth which is slightly dampened with a good weapon oil.

Regularly (after approx. 250 shots fired) clean your weapon by using maintenance cylinders and cleaning pads (see special accessories), this will ensure that the function of your rifle is ensured for a long time. Every now and then, spray a thin layer of weapon oil through the openings of the breech and the hinged magazine holder into the inside of the weapon.

For the lubrication of the seals inside the stabbing compartment, apply the same procedure.

## 13. Problems

problem	possible cause	gas cylinder empty	barrel dirty	gas cylinder not stabbed	extreme temperatures	wrong ammunition	pellets loaded upside down	pellet in the loading opening (chapter 7)	sights not properly adjusted
inferior accuracy	●	●		●	●	●		●	
weapon does not fire	●		●	●		●			
low projectile velocity	●	●		●	●	●			
magazine holder cannot be closed					●		●		

## 14. Changes and modifications of the weapon



**ATTENTION!** All parts and components of the weapon were designed in a way that they function and perform in an optimal way all the time. Changes and modifications of the design or tuning may lead to a faulty function and may result in a weapon which is dangerous to use. Unauthorized modifications of the weapon cause the warranty to become null and void.

## 15. Repair of Walther-weapons

**CAUTION!** A defect weapon is dangerous. It should be stored in a safe place so that nobody can use it before it has been repaired. You should not try to repair a weapon yourself as this is difficult, and a faulty assembly can lead to dangerous malfunctions.



Only allow qualified gunsmiths or authorized dealers to check and repair your weapon!

## 16. Warranty for Walther-weapons

Within the legally determined warranty period (beginning with the date of purchase), the WALTHER company will repair or replace your weapon free of charge provided the cause for the defect is faulty workmanship or manufacture. The weapon should be handed to an authorized dealer and should be accompanied by a written description of the problem and a proof of purchase.



**IMPORTANT!** During transport, a weapon must always be unloaded, the safety must be engaged and the gas cylinders must be removed.

Firearms are subject to a certain wear. In case of intensive use, they may show signs of wear and tear without suffering any reduction of functional reliability. The drum magazines accommodating the diabolos are exposed to high mechanical stress and may have to be replaced, when necessary. (Please refer to the Special Accessories section for details.)

## 17. General handling cautions

You should be thoroughly familiar with the proper and safe use of your weapon. Bear in mind that this rifle has a very high bullet velocity which requires extra care. Also bear in mind that, in respect to the safe handling and use of weapons, that touching the weapon means handling it.

- in Germany, a firearms certificate is required for the use of this weapon in the public
- treat every weapon as if it was loaded
- always engage the safety when loading the weapon so that no unintentional discharge can occur. Always keep your fingers away from the trigger, only touch the trigger if you intend to shoot.
- only use ammunition and gas cylinders expressly cleared for this weapon
- always point the muzzle in a safe direction.
- this rifle may only be discharged in your own house, on official rifle ranges and on private ground as long as it is made sure that the projectile cannot leave the premises. The maximum range of the projectile is approx. 820 feet.
- never transport a loaded weapon. It should only be loaded when you intend to fire it.
- never aim at humans or animals. Avoid ricochets. Never fire at smooth and hard surfaces or water.
- make sure that your target and the surrounding area are safe before you fire.
- always make sure your weapon is unloaded before you transport it or hand it over to another person.
- make sure that you always have full control over the muzzle, even when you stumble or fall.
- wear protective shooting glasses when you fire the rifle - this is a safety precaution.
- always store your weapon in unloaded condition and keep it away from unauthorized persons (untrained people, children, minors), keep ammunition and gas cylinders separate from the weapon.
- only hand this weapon (accompanied by its operating instructions) over to persons who are older than 18 years and who are thoroughly familiar with its use
- repairs and modifications should only be done by an authorized dealer or a qualified gunsmith.
- never leave a loaded weapon unattended.
- unload your weapon before you give it to other people.

## 18. Technical data

	<b>Lever-Action long</b>	<b>CO<sub>2</sub>-rifle</b>	<b>Lever-Action short</b>
function	:		
calibre	:	.177 (4.5 mm) pellets	
magazine capacity	:	8 pellets	
overall length	:	972 mm	872 mm
weight	:	3400g	3300g
muzzle velocity	:	up to 557 feet/sec.	up to 557 feet/s
barrel length	:	19,1" (480mm)	15,2" (380mm)
propellant	:	2 gas cylinders 12 g	
safety	:	- pushbutton safety which acts on the hammer notch - hammer safety (sliding safety)	

## 19. Spare parts

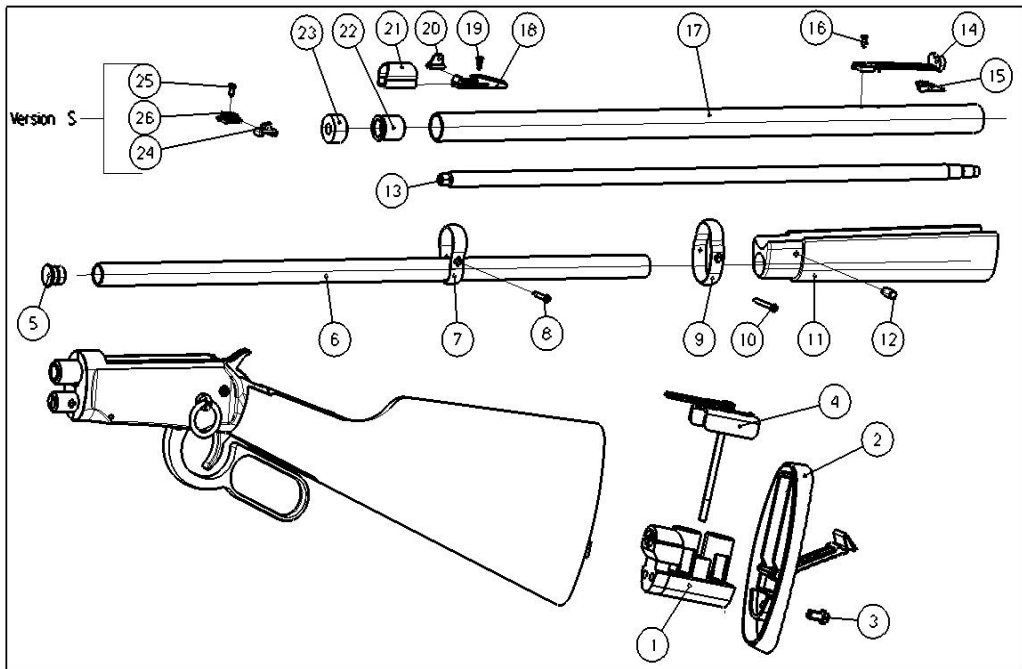

## Spare parts list

Pos.	designation	article no.	price
1	stabbing case	460.60.01	
2	buttplate, complete	460.20.34	
3	screw	460.20.49.0	
4	clamping plate with screw	460.60.08	
5	plug	460.20.20.1	
6	loading tube, mod. long	460.20.07.0	
	loading tube, mod. short	460.21.01.0	
7	barrel band	460.50.05.1	
8	screw for barrel band	460.50.06.0	
9	rear barrel band	460.20.17.1	
10	screw for band	460.20.21.0	
11	forend	460.20.06.1	
12	knurled nut	460.20.57.1	
13	barrel 19" mod. long	460.50.01.1	
	barrel 15" mod. short	460.51.01.1	
14	sight	460.70.01.1	
15	elevation adjustment	460.70.02.1	
16	screw for sight	303.20.28.0	
17	barrel sleeve mod. long	460.50.02.0	
	barrel sleeve mod. short	460.51.02.0	
18	foresight base, mod. long	460.70.03.1	
19	screw for foresight blade, long	303.20.28.0	
20	foresight blade mod. long	460.70.04.1	
21	foresight hood	460.70.05.1	
22	barrel sleeve nut	460.50.03.0	
23	muzzle	460.50.04.1	
24	foresight blade mod. short	460.71.02.1	
25	screw for foresight blade	303.20.28.0	
26	foresight base mod. short	460.71.01.1	

# Special accessories for model Lever Action

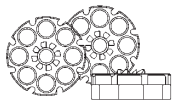

## Rotary magazine

3 in a package  
item no. : 416.120

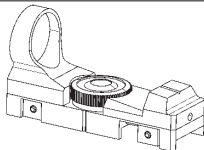

## Point Sight "Competition"

brightness adjustable in 11 steps,  
mounting: adapter rail and 11 mm  
scope rail  
overall length: 100 mm  
weight: 55 g

item no. 2.1016

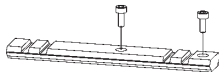

## Adapter rail

for sight: 2.1012  
2.1016

item no. 460.112

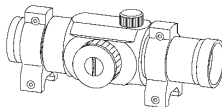

## Red-Dot sight "Top-Point"

brightness adjustable in 11 steps,  
with scope rings  
overall length: 138 mm  
weight: 210 g

item no. 2.1012

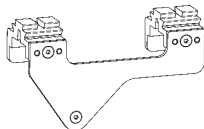

## Sight Mount

for 11mm and 22mm dove  
tail guide



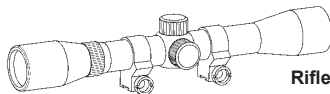

item no. 460.113

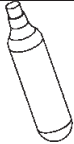

## Rifle Scope 4x32

item no. 2.1500

# Special accessories for model Lever Action

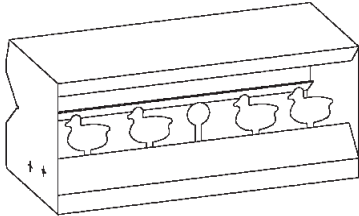
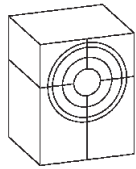
 <p><b>CO<sub>2</sub> gas cylinders</b> packet of 10 for all CO<sub>2</sub> weapons item no.: 4.1682</p> <p><b>maintenance cylinders for CO<sub>2</sub> weapons</b> packet of 5, for all CO<sub>2</sub> weapons item no.: 4.1683</p>	    <p><b>Pellets "Match"</b> cal. .177 (4.5 mm) smooth packet of 5,000 4.1951</p> <p><b>Pellets "Spitz"</b> cal. .177 (4.5 mm) copper-plated packet of 5,000 4.1952</p> <p><b>Pellets "Finale Match"</b> cal. .177 (4.5 mm) for air pistols packet of 5,000 4.1940</p> <p><b>Pellets "High Power"</b> cal. .177 (4.5 mm) Luftpistolenkugeln packet of 4,000 4.1675</p>
<p><b>Cleaning plugs</b>                      item no.: 3.2095</p>	
<p><b>Cardboard targets</b></p> <p>suitable for backstop box 3.2071 17 x 17 cm, packet of 250 item no.: 3.2095</p>	<p><b>Backstop box</b> for cardboard targets 10 - 17 cm item no.: 3.2071</p>
 <p><b>Falling targets range</b> 4 hinged targets fall down when being hit. A hit on the central target re-erects all four targets. Dimensions: 49 x 22 x 30 cm item no.: 3.2080</p>	 <p><b>Five pack set, cal. .177 (4.5 mm)</b> Match pellets, knurled Match pellets, smooth Pointed pellets, copper plated Pointed pellets, knurled Hollow Point Semi Wadcutter, smooth 500 each item no.: 4.1950</p>
<p><b>Protective shooting glasses</b></p> <p>yellow    Art.-Nr.: 2.5013 clear     Art.-Nr.: 2.50133</p>	<p><b>Cordura magazine pouch</b> with Vortexâ fastener, black item no.: 3.1554</p> <p><b>Cordura belt</b>, with slide-on pouch for magazines and pellets, loops for gas cylinders attached to the belt item no.: 3.1530</p>

# UMAREX®

## Service:

Umarex Sportwaffen

Postfach 2720  
59717 Arnsberg

Neheim, Donnerfeld 2  
59757 Arnsberg

Telefon 02932 / 638-01  
Telefax 02932 / 638-222

E-Mail: [sales@umarex.de](mailto:sales@umarex.de)  
Internet: [www.umarex.com](http://www.umarex.com)



