

Safety and instruction manual

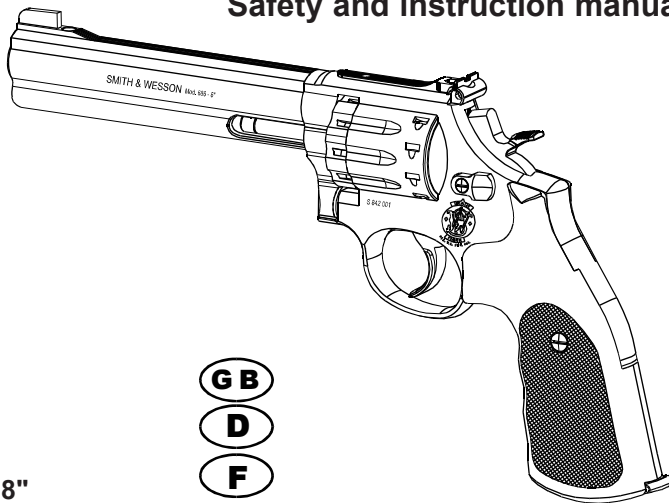

CO₂ -Revolver
SMITH & WESSON
Mod. 586 / 686 -6" / 4" / 8"
cal. 4,5 mm (.177)



Pat. applied for



You must be 18 years old to purchase this air gun. Warning: Carefully read and follow these instructions before using this air gun. If there is anything you do not understand, get help from someone qualified in the safe handling of guns. It is your responsibility to follow the rules of safe use and ownership of this air gun.



This symbol marks safety warnings in this instruction manual. When you see this symbol you should pay close attention to the warning.



Read the instruction manual carefully. Only load the gun immediately before you intend to shoot. If you have charged the gun and will not shoot, discharge the gun as described. Only an unloaded gun with the safety on is really safe. Accidents can happen very quickly! Warning: If this gun is carelessly or improperly handled, unintentional discharge could result causing injury, death or damage to property.

Please be very careful when shooting!

The chapter "Safe aiming and shooting" in this instruction manual will inform you about the rules for safe shooting. READ THIS CHAPTER. Follow these rules and be sure that everybody handling this gun is familiar with the rules. Also read the chapter "Safe handling of guns" to avoid accidents.

Your air gun should be treated with the same respect as a firearm. Always be aware that the most important safety aspect of a gun is the shooter. All safeties are mechanical and the shooter is responsible for its proper use. Do not rely on mechanical safeties, think in advance and avoid situations which may lead to an accident.

Every gun differs in function. You should never shoot a gun you are not familiar with. Read the following instruction manual and practice safely handling your gun prior to loading it.

Cautions for safe shooting:

- | | | | |
|----|--|-----|------------------------------|
| 1. | Know the components of your new gun | 9. | Problems |
| 2. | Inserting and replacing the CO ₂ - cylinder | 10. | Modifications to the gun |
| 3. | Loading and unloading CO ₂ - revolver | 11. | Repairs |
| 4. | Safe aiming and shooting | 12. | Warranty |
| 5. | Special features of CO ₂ - gas | 13. | Safe gun handling |
| 6. | Adjusting the sights | 14. | Technical data |
| 7. | Storage | 15. | Spare parts list and drawing |
| 8. | Maintenance | 16. | Mounting 4" and 8" barrels |

Never leave an unattended gun loaded and ready to fire!



Always keep and carry your gun unloaded. Be sure that there is no pellet in the barrel. During storage, remove the pellet cylinder and the CO₂ gas cylinder and store them in a separate location. Keep out of reach of children and unauthorized person.

1. Know the components of your new CO₂ -revolver

It is your responsibility to become familiar with the component parts of your gun. You will understand this instruction manual properly with this knowledge.

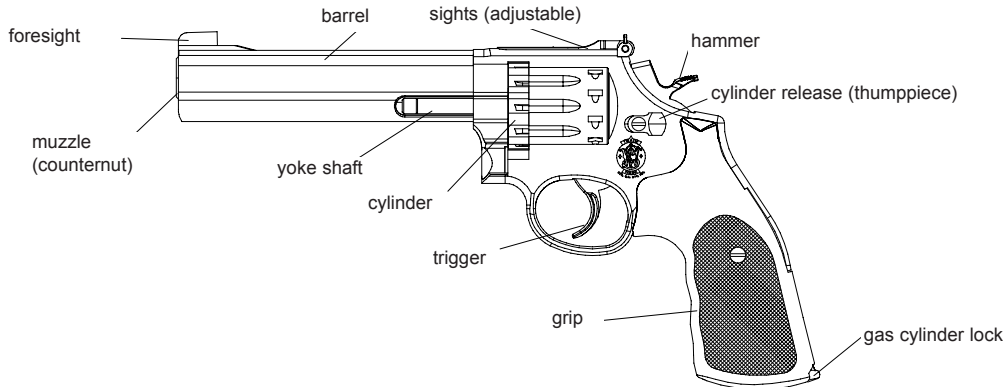

2. Inserting and changing the CO₂ -cylinder

A. Inserting a CO₂ -cylinder



CAUTION: When piercing a gas cylinder it is very important that the muzzle of the gun points in safe direction..

Note: Only use CO₂-cylinders which contain 12g, never use cylinders with other gasses!

Open the gas cylinder lock, then remove the right grip by lifting it off the frame (fig. 1.1). Turn the gas cylinder retaining screw all the way down and insert the gas cylinder with its slender end first into the frame (fig. 1.2).

Turn the gas cylinder retaining screw up until it touches the gas cylinder (do not tighten it as this may damage the gas cylinder seal). Replace the grip by putting it in the right place and pressing it down. Now close the gas cylinder lock (fig. 1.3). The CO₂ -cylinder has now been pierced and sealed.

In order to check that the CO₂-cylinder has been pierced properly, make sure that the gun is unloaded and then fire it with the muzzle of it pointing in a safe direction. If the gun fails to fire repeat the above described procedure of inserting the CO₂-cylinder.

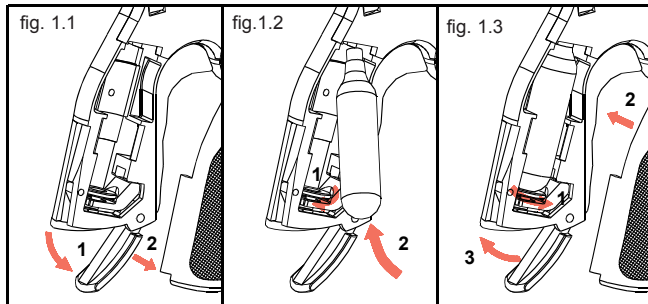

Warning: Do not use force to insert the CO₂-cylinder. If you are not going to use the weapon for an extended period, we recommend removing the CO₂-cylinder in order to prevent strain on the valve.

B. Removal of a gas cylinder

Hold the weapon with one hand by its grip. Use the other hand to open the gas cylinder lock. Now remove the right grip by lifting it off (fig. 1.1). Turn the gas cylinder retaining screw all the way down (Bild 1.2). The gas cylinder can now be removed.



WARNING: Keep face and hands in a safe distance and use caution when removing the CO₂-cylinder, escaping CO₂ gas can cause frostbite.



WARNING! CO₂-cylinders can explode in temperatures above 122 degrees Fahrenheit. Do not dispose of gas cylinders in a fire. Do not store gas cylinders in temperatures above 122 degrees Fahrenheit. Do not use spent CO₂-cylinders for any other purpose. Do not leave CO₂-cylinders in a automobile in direct sunlight.

3. Loading and unloading the CO₂-revolvers



Caution! Never use steel shot (so-called BB's), pointed steel projectiles, airgun darts or similar unsuitable projectiles.

A. Loading the CO₂-revolver

- The cylinder (pellet magazine) can be swung out to the left by pressing the thumbpiece of the cylinder release mounted on the left side of the frame (fig. 2.1).

- Remove the cylinder from its shaft and load it with pellets cal. .177 (4,5mm). (fig. 2.2)

In order to prevent malfunctions make sure that all pellets are loaded with the blunt end forward and flush with the edge of the cylinder or, even better, that they are slightly countersunk.

- Replace the loaded cylinder on its shaft, with the ratchet to the rear, then press it back into the frame (fig. 2.3). The gun is now ready to fire.



WARNING! Do not put your hand over the muzzle! Do not put your finger on the trigger! Make sure that the muzzle is pointed in a safe direction! Never aim at people or pets.

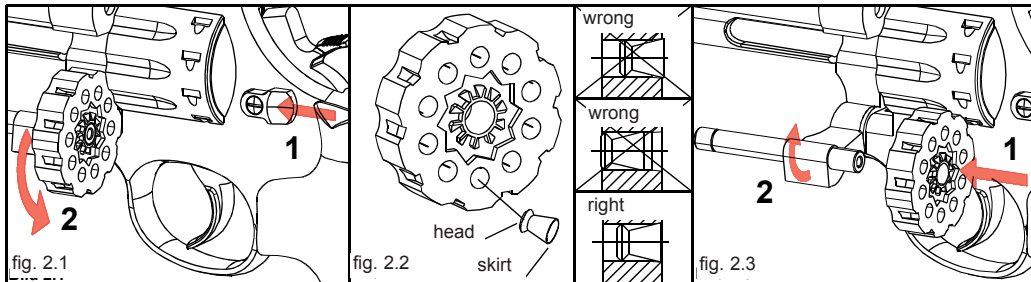

B. Unloading the revolver

Push the thumbpiece of the cylinder release forward and swing the cylinder out of the frame (fig. 2.1).

Remove the cylinder and remove all pellets from it with the aid of a cleaning brush or another simple tool.



CAUTION! Never use a sharp metal tool to remove pellets. Never use force when swinging out the cylinder. Damaged cylinders or barrels lead to malfunctions of the gun.

- Check the barrel in order to ensure that the gun is entirely unloaded.
- If a pellet is left in the barrel remove it with cleaning brush.
- If a pellet got stuck in the gap between the cylinder and the barrel push it back into the cylinder with the cleaning brush.
- Do not attempt to use a fired pellet a second time. It may damage cylinder and barrel.

4. Safe aiming shooting



WARNING: Always point the muzzle of the gun in a safe direction. Never aim at people or pets. Always handle your weapon as if it is loaded and ready to fire.

Make sure the safety is On, insert the CO₂-cylinder and load the pistol as described.



WARNING: Be very careful where you aim this high efficiency gun. Aim only at objects that cannot be penetrated. Never shoot at hard surfaces or water. A Diablo pellet may ricochet and travel in another direction.

After you have ensured yourself that target, pellet trap and the surrounding area are clear you may shoot: Exercise a steady, but not too hard pressure on the trigger until the gun fires.

The weapon will function in either double-action or single-action mode.

To fire in double-action, apply steady pressure to the trigger until the pistol fires. To fire in single-action, first cock the hammer to activate single-action mode, then apply steady pressure to the trigger until the pistol fires.

For rapid-fire shooting we recommend the double-action mode, for more precise aimed shooting we recommend the single-action mode.



CAUTION! Do not assume that the gun is unloaded if it fails to fire properly!

WARNING! Insufficient CO₂-pressure could cause a pellet to lodge in the barrel. See chapter 5, "Special features of CO₂-gas" for further instructions.

If a pellet fails to be shot after execution of the operation steps mentioned before this could be due to a stoppage.



A stoppage is dangerous !

- Make sure that no pellet is jammed in the gap between cylinder and barrel.
- Swing out the cylinder and remove it from its shaft.
- Make sure that the rear part of the pellet is flush with the edge of the cylinder or that it is slightly countersunk.
- Make sure that no pellet is in the barrel.
- Place an empty cylinder on the cylinder shaft and swing it back into the frame.
- Pull the trigger in order to check that there is sufficient CO₂-pressure.
- If necessary, change the gas cylinder and reload the gun according to the above described procedure.



WARNING! Keep hands and face at a safe distance from the CO₂-cylinder. Escaping CO₂-gas can lead to frostbite!

5. Special features of CO₂ - gas

There are occasions when a CO₂ -gun may be subjected to abnormal conditions that can produce effects on the guns performance. These conditions include operation and/or storage of the gun at temperatures that are considerably higher or lower than normal outdoor temperatures (60°-70°F)/(15°-21°C), as well as conditions of rapid fire.



Caution! High temperatures can produce pressure in the CO₂-cylinder that is considerably higher than normal operating pressure. Such increased pressure may prevent the gun from firing and may result in permanent damage to the gun. The maximum operating or storage temperature should not exceed 105°F (40°C). This temperature can easily be reached if the gun is left directly in the sun on a bright, sunny day. Therefore, the shooter should not expose the gun to high temperature conditions or direct in the sunlight for any extended period of time.

2. Rapid-fire shooting will quickly chill a CO₂ cartridge leading to reduced pressure and pellet velocity.
3. Rapid fire shooting leads to reduced shooting efficiency.
4. As the cartridge loses pressure you will notice several characteristics:
 - A) The sound of the actual shot will not be as loud.
 - B) Pellet impact will be lower on the target.



WARNING: Continued shooting when the cartridge has lost pressure could cause a pellet to lodge in the barrel!
See the warning on stoppages.

6. Adjusting the sights

Aim at a safe target and line-up the front sight in the middle of the rear sight. (see fig. 3)

The point of impact can be changed by adjusting the elevation and windage of the sight.

Adjustable sights are standard fitting on the S&W Mod. 586 / 686 CO₂-revolver.

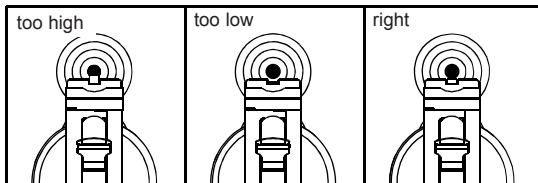

fig. 3

Sights adjustment

Elevation and windage adjustment of the sight is done by turning the elevation and windage adjustment screws by means of a screwdriver. (fig. 4)

- elevation adjustment
point of impact too high: turn screw clockwise
point of impact too low: turn screw anti-clockwise
- windage adjustment
point of impact too far left: turn screw clockwise
point of impact too far right: turn screw anti-clockwise

fig. 4

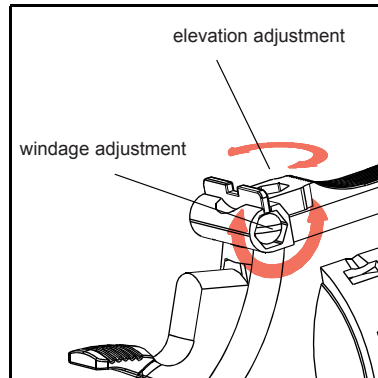

7. Storage



Never leave a loaded gun unattended!

Always store your gun unloaded. Remove the pellet cylinder and check to insure that no pellet remains in the barrel. Remove the CO₂-cylinder. Store your weapon in a separate location from the pellets and CO₂-cylinder. Keep out of reach of children and unauthorized persons.

8. Maintenance

With the proper maintenance your gun will give you years of pleasant shooting.



Caution! Do not attempt to clean your gun without first having put the safety on, removing the pellet cylinder and CO₂-cylinder and checking to insure that no pellet remains in the barrel.

Clean the surface of your pistol with a soft cloth and gun oil.

To insure continued proper function, place 2-3 drops of gun oil on the gas cylinder lock, yoke, and cylinder release after every 250 shots. Perfect long-lasting operation is guaranteed from your gun if it is cleaned at regular intervals (250 shots) with maintenance capsules and cleaning slugs (see chapter on special accessories).

9. Problems

Problems	POSSIBLE REASONS	CO ₂ -cylinder is empty	barrel is dirty	CO ₂ -cylinder is defective	extreme temperatures	incorrect pellets	pellets inserted in the cylinder incorrectly	cylinder not locked	incorrect sight adjustment
Bad shooting efficiency	●	●		●	●	●		●	
Gun does not function	●		●	●		●	●		
Low pellet velocity	●	●		●	●	●			

10. Modifications to the gun



CAUTION! This weapon has been designed and manufactured for optimum function and efficiency. Do not make any modifications as they could lead to malfunctions or unsafe conditions.

11. Repairs

Do not attempt to repair this pistol if it needs service. Incorrect assembly could lead to dangerous malfunctions.



Repairs should only be completed by Umarex authorized service.

12. Warranty

Within one year from date of purchase will repair or replace the gun free of charge if the defect was not caused by you. Return the gun to the authorized dealer where you have bought it.



WARNING: When carrying the gun make sure that the safety is ON, the gun is unloaded and the CO₂-cylinder is removed.

13. Safe gun handling

It is your responsibility to be familiar with the safe and correct use of your weapon.

- Always handle your weapon as if it is loaded.
- When loading your gun, insure that the safety is ON, and do not put your finger near the trigger.
- Use only the recommended pellets and CO₂ cylinders.
- Always point the muzzle in a safe direction.
- Remember that this is a high efficiency weapon capable of propelling a pellet over 400 yards.
- Always check a gun to see if it is loaded when removed from storage or received from another person.
- Never transport your weapon when loaded.
- Do not aim at people or pets. Never shoot at a hard surface or water.
- Be sure that your target and backstop are safe.
- Make sure you can control the direction of the muzzle if you stumble or fall.
- Unload your airgun before giving it to another person.
- Always wear shooting glasses when shooting your airgun.
- Always store your gun in a secure location out of the reach of children or unskilled users.
- Store your pellets and gas cylinders in a separate location.
- When transferring this weapon be sure to include this instruction manual.
- Repairs to this airgun should only be done by Umarex authorized service.
- Never leave a loaded gun unattended.

14. TECHNICAL DATA

version with 6" / 4" / 8" barrel

S & W Mod. 586 / 686

Function	CO ₂ -revolver
Calibre	cal. .177 (4,5 mm) pellets
Cylinder capacity	10 rounds
Overall length	(285 / 235 /335 mm)
Weight	(1250 /1130 /1400 g)
Muzzle velocity	393 ft (120 m/s)
Barrel length	6" / 4" / 8" rifled barrel
Propellant	CO ₂ -cylinders 12 g
Safety	automatic internal hammer safety

15. Part illustration and list

Pos.	art.- no.	Description
1	448.20.01.0	frame, blued
	448.21.01.0	frame, nickel plated
2	448.20.02.0	cover plate, blued
	448.21.02.0	cover plate, nickel plated
3	347.20.06.0	cover plate screw
4	448.20.22.0	valve bushing
5	416.20.04.2	O-ring
6	448.20.25.1	valve nozzle
7	416.20.06.1	valve nozzle spring
8	448.60	valve
9	300.40.08.0	cylinder stop pin
10	448.20.27.0	cylinder stop
11	448.20.33.1	cocking lifter spring
12	448.20.12.0	hand
13	448.20.32.1	hand spring
14	318.200.02.3	conveyor link pin
15	448.20.11.1	conveyor link
16	373.20.16.3	safety plate pin
17	448.20.03.0	trigger
18	448.20.04.1	trigger spring
19	448.20.28.3	pin for trigger
20	448.20.17.0	safety plate
21	448.20.18/19.1	pair of grips, plastic
22	448.20.10.0	gas cylinder lock
23	448.20.09.3	pin for gas cylinder lock
24	448.20.08.0	pressure plate
25	416.20.28.1	gas cylinder screw
26	417.20.37.1	pressure plate spring
27	346.73.03.3	release lever pin
28	448.20.07.0	release lever
29	448.20.30.1	release lever spring
30	448.20.21.0	pressure lever
31	373.20.15.1	locking bolt spring
32	448.20.15.1	locking bolt
33	448.20.14.0	unlocking lever

Pos.	art.- no.	Description
34	448.20.05.0	hammer
35	448.20.29.1	hammer spring
36	448.20.06.1	cocking lifter
37	448.20.31.3	flat head screw
38	448.20.26.1	spring
39	448.20.13.1	cylinder release
40	448.40.04.0	cylinder
41	448.40.03.0	cylinder rod
42	448.40.01.0	yoke, blued
	448.41.01.0	yoke, nickel plated
43	448.40.02.0	yoke shaft
44	448.20.16.0	closing lever
45		
+		
46	448.102	Interchangeable barrel system 6", blued
	448.103	Interchangeable barrel system 6", nickel plated
	448.100	Interchangeable barrel system 4", blued
	448.101	Interchangeable barrel system 4", nickel plated
	448.104	Interchangeable barrel system 8", blued
	448.105	Interchangeable barrel system 8", nickel plated
47	448.70.03.0	foresight 3,2 mm
48	448.70.04.0	foresight 2,5 mm
49	448.70.05.0	foresight 2,8 mm
50	370.20.26.3	countersunk screw
51	448.50.03.1	counternut
52	448.50.04.1	barrel mounting tool
53	448.70.01	sights
54	373.20.17.3	Pin

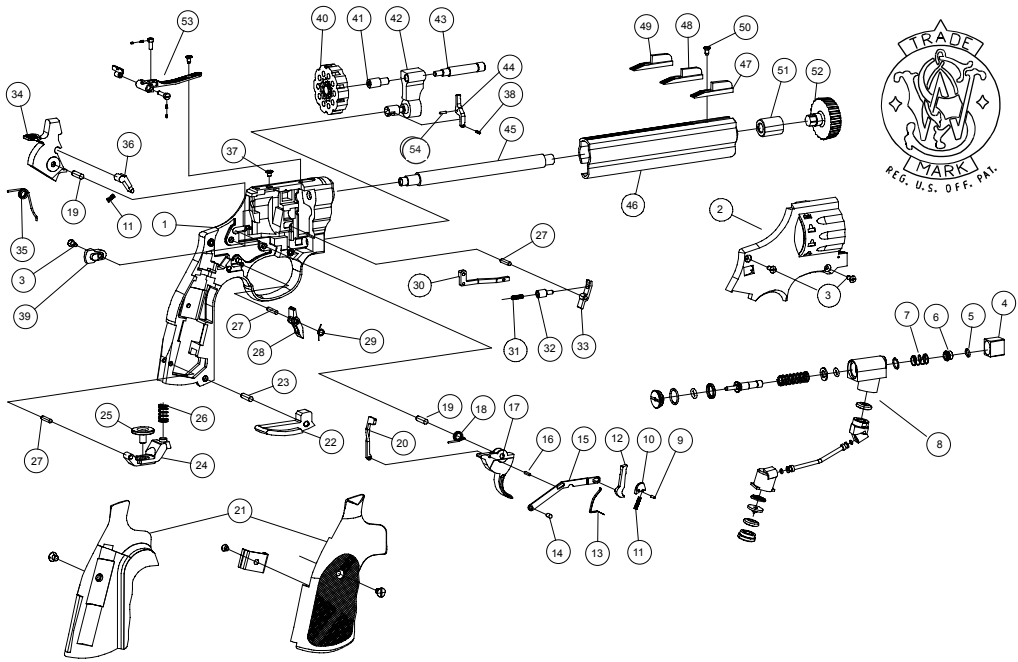

16. Mounting 4" and 8" barrels





Unload the CO₂-revolver as previously described. Loosen the counternut by using the barrel mounting tool. Remove the barrel sleeve and unscrew the insert barrel. Now fit the desired insert barrel, finger-tighten it and fit the appropriate barrel sleeve. Finally screw the counternut onto the insert barrel and finger-tighten it with the barrel mounting tool.

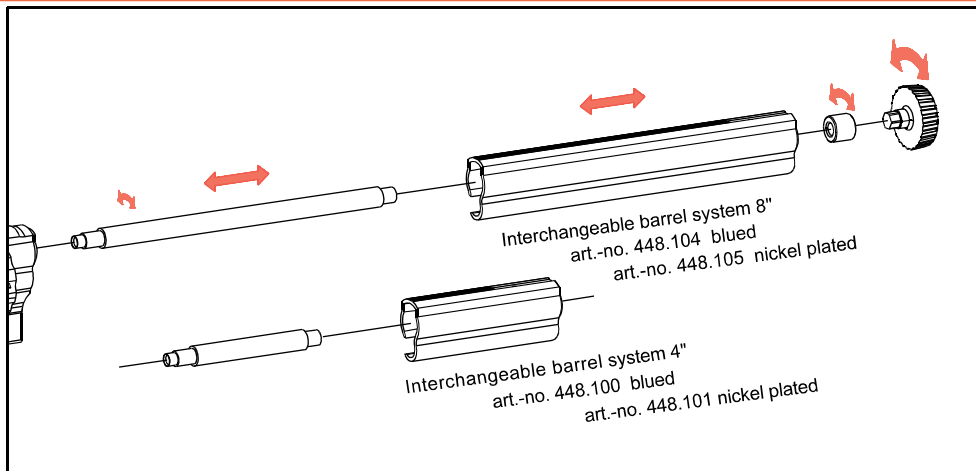

Caution! Never fire the CO₂-revolver with the barrel not fully mounted. Make sure the muzzle of your CO₂-revolver points in a safe direction when mounting the barrel, and also make sure that there is no unintentional operation of the trigger.

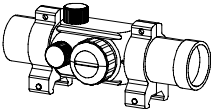
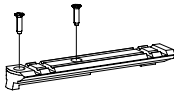
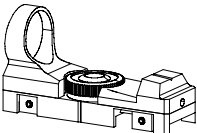
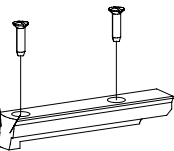
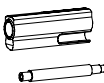

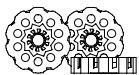



Special accesories for CO2 Revolver S & W Mod. 586/686

	<p>Red-Dot-Sight "TopPoint" Brightness adjustable in 11 steps, with mount rings Length: 138mm Weight: 210g</p> <p>Part. no.: 2.1012</p>	<p>Weaver rail</p>  <p>For sights: 2.1012 2.1016 length: 110 mm, weight: 12,5 g</p> <p>Part. no.: 448.108</p>
	<p>Point Sight "Competition" Brightness adjustable in 11 steps, with adapter rail mount. and 11mm dove tail guide, Length: 100mm Weight: 55g</p> <p>Part. no.: 2.1016</p>	<p>Scope rail with 11mm dove tail guide For sight: 5.8051 2.1016 length: 88mm, weight: 4,5g</p> <p>Part. no.: 448.107</p> 
	<p>Red dot optical sight Brightness adjustable in 2 steps, with adapter rail mount. and 11mm dove tail guide Length: 112mm Weight: 60 g</p> <p>Part. no.: 5.8051</p>	<p>Interchangeable barrel system 4"</p>  <p>blue Part.no.: 448.100 nickel plated Part.no.: 448.101</p> <p>Interchangeable barrel system 6"</p>  <p>blue Part.no.: 448.102 nickel plated Part.no.: 448.103</p>
	<p>Cylinder magazine</p> <p>Pack of 3</p> <p>Part. no.: 448.106</p>	<p>Interchangeable barrel system 8"</p>  <p>blue Part.no.: 448.104 nickel plated Part.no.: 448.105</p>

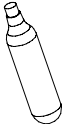
Subject to change without prior notice

Special accesories for CO2 Revolver S & W Mod. 586/686

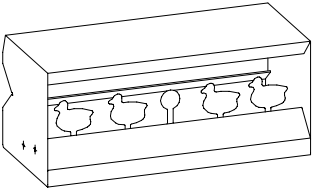
 <p>CO2-Capsules Pack of 10; contents 12g; for all CO2 airguns Part. no.: 4.1682 Maintenance capsule de CO2 Pack of 5; for all CO2 airguns Part. no.: 4.1683</p>	    <p>Waisted Match pellets "Diablo" cal. 4,5mm (.177) smooth(5000 Pack)4.1951</p> <p>Pointed waisted pellets "Diablo" cal. 4,5mm (.177) copper(5000 Pack) 4.1952</p> <p>Finale-Match cal. 4,5mm (.177) Air pistol pellets (5000 Pack) 4.1940</p> <p>High Power Pellet cal. 4,5mm (.177) Air pistol pellets (400 Pack) 4.1675</p>
<p>Cleaning slugs Part. no.: 3.2055</p>	
<p>Targets</p> <p>17 x 17 cm,for Pellet trap 3.2071 per 250 pieces</p> <p>Part. no.: 3.2095</p>	<p>Pellet trap</p> <p>for targets 10 - 17 cm</p> <p>Part. no.: 3.2071</p>
 <p>Five Pack Set, cal. 4.5mm (.177)</p> <p>Waisted pellets "Diablo",ribbed; Waisted Match pellets "Diablo", smooth; Pointed waisted pellets "Diablo", cooper; Pointed waisted pellets "Diablo", ribbed; Hollow Point Semi Wadcutter, smooth (a 500 pieces) Part. no.: 4.1950</p>	
<p>Magnetic Pellet Trap</p> <p>4 targets are knocked down when a hit is scored. When the center target is hit; all targets return to the upright position. Dimensions: 49x22x30 cm Part. no.: 3.2080</p>	<p>Hard shell case Part. no.: 448.117 S & W belt holster "Quick Defense" Made from black leather. Method of carriage: FBI or Cross-draw</p> <p>S & W competition holster "Speed Machine" Short travel for fast draw, adjustable draw angle and gun hold</p> <p>Ammunition belt, with slide-on pouches for magazine and diabolos, 5 loops on belt for gas cylinder</p>
<p>Protective Shooting glaces</p> <p>yellow Part. no.: 2.5013 clear Part. no.: 2.50133</p>	<p>Part. no.: 3.1547</p> <p>Part. no.: 3.1546</p> <p>Part. no.: 3.1530</p>

Subject to change without prior notice



Service:

Umarex Sportwaffen
GmbH & Co, KG

Postfach 2720

D-59717 Arnsberg

Donnerfeld 2

D-59757 Arnsberg

Telefon: 02932 / 638-01

Telefax: 02932 / 638-222

E-Mail: sales@umarex.de

Internet: www.umarex.com